

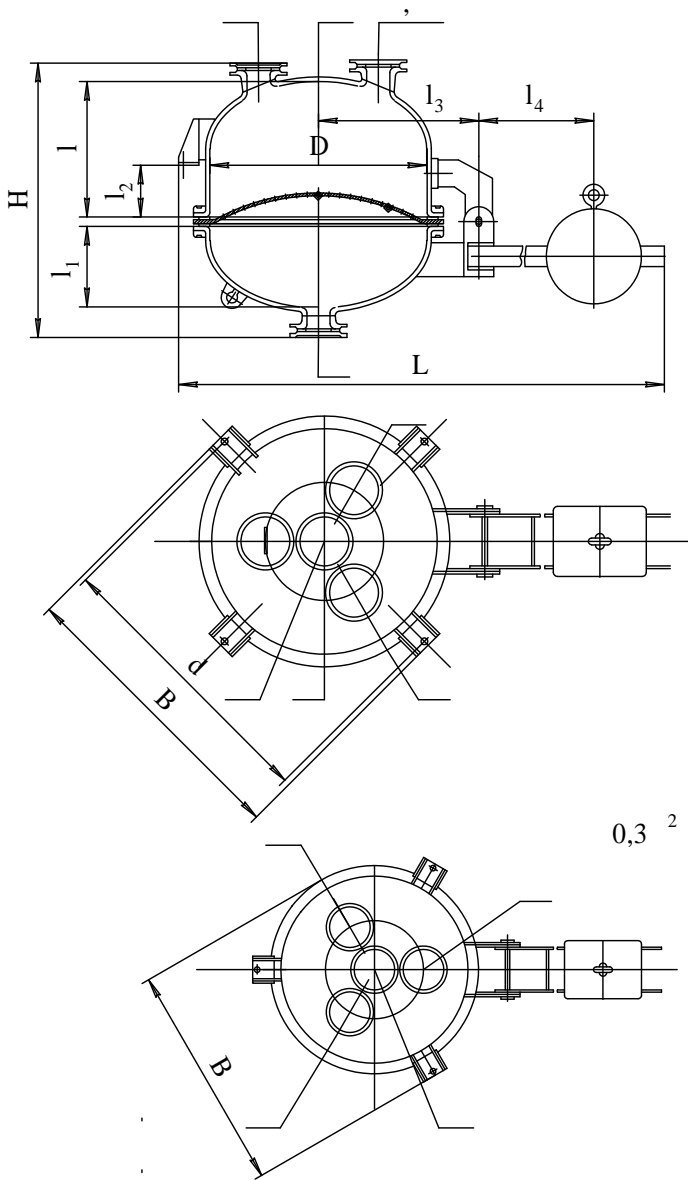

(-)



1-4

, (/ ²)-0,4(4,0)

- :
 - -20 +200 °
 - -20 +150 °
 :
 =11 - -20 +130°
 =12 - -20 +110°
 =13 - -20 +90°
 =14 - -20 + 80°
 - -20 +200°

3					
, ,					
0,2	100	65	65	65	-
0,3	100	100	100	100	-
0,4	150	100	100	100	-
0,56	100	100	100	100	-
0,8	150	100	100	100	100

	, 2	, 3	D,	l,	l ₁ ,	l ₂ ,	l ₃ ,	l ₄ ,	d ₁				
										L ,	B ,	H ,	
0,2-11-12-01	0,2	0,063	500	360	205	130	500	700	667	1160	697	815	285
0,3-11-12-01	0,3	0,06	600	320	215	190	470	700	780	1750	765	800	455
0,4-11-12-01	0,4	0,26	700	540	240	230	520	640	870	1970	915	1020	570
0,56-11-12-01	0,56	0,14	800	427	265	200	577	690	1028	2675	1072	905	805
0,8-11-12-01	0,8	1,0	1000	1130	315	510	670	1000	1212	2020	1256	1680	1140